

od5

High-end outdoor Intercom station



Ready for
Symphony
Cloud

Weather-
proof
IP65

Impact-
proof
IK08

Modular
solution

5" touch
display

Future-proof
system

Adaptive solutions for outdoor areas

Touch display equipped Intercom stations by Commend are suitable for any type of application requiring intuitive, yet precise user interaction. While offering standard menus for features such as subscriber lists, the graphical user interface can be adjusted to suit the user's requirements. Options range from creating custom menus to integrating interactive on-screen elements such as video feeds.

High-performance processors turn the od5 into a communication powerhouse. With a dedicated emergency mode feature-set, it transforms from everyday use into an emergency station for managing crises events. This means perfect preparation to meet upcoming standards – such as Advanced Security Building Intercom Systems (ASBIS) according to EN 62820-2.

These high-end Intercom stations are crafted using high-quality materials, including glass and anodised aluminium. Thanks to their timeless look, they are ideally suited for use as multi-functional Intercom stations with advanced security mode for modern office buildings.

Ready for Symphony Cloud Services

The Intercom stations can be connected to Symphony and use its services. Symphony is the world's first cloud-based Intercom platform with "Privacy and Security by Design". Visit the Symphony website to find out about the services currently available and if they are already offered in your country.

symphony.commend.com

Features and highlights

- Suitable for indoor and outdoor use
- High protection against vandalism (mechanical impact resistance IK08)
- 3 mm thick, tempered front glass
- Innovative sound concept with two lateral loudspeakers and two digital MEMS microphones
- Crystal-clear sound with up to 20 kHz speech quality and high volume
- Durable and resistant to wind and weather thanks to high-quality components and IP65 rating
- Robust, ultra-bright 5" touch display with brilliant colour reproduction
- Anti-reflective glass surface for good readability of the display – even in direct sunlight
- High-resolution wide view angle video camera
- Sophisticated housing concept for simple, safe installation
- Surface and flush mount kits with locking mechanism
- OpenDuplex® for natural, hands-free communication
- Permanent line and function testing
- Easy to extend with add-on equipment via USB interface
- Motion detection for triggering action sequences

Key benefits at a glance

Crystal clear sound: two loudspeakers and high-quality audio technology ensure a perfect listening and speaking experience.

Enhanced overview: the built-in high-resolution video camera has a picture-perfect viewing angle that allows it to capture persons who are not at eye-level with it, such as wheelchair users or children.

The Intercom stations are optimally protected against vandalism (IK08 rating).

The waterproof housing predestines the od5 for outdoor use (protection class IP65).

A question of attitude: the stations are quick and easy to configure individually over the Commend web interface.

The 5" colour touch display is individually configurable and shows the live image from the other station during video calls.



CONCERTO always strikes the right note, with two MEMS microphones making sure that no interfering background noise gets through. The software and special audio algorithms provide an exceptionally high level of speech intelligibility.

Accessories

Gypsum wall/panel kit XDX FB

With the gypsum wall/panel mount kit XDX FB, an Intercom station can be installed e.g. in a drywall.



Surface mount kit XDX SH

With the surface mount kit XDX SH, an Intercom station can be mounted on a wall. The XDX SH is primarily intended for subsequent installation on a wall or for installation on thin walls.



Flush mount box XDX FBS

With the flush mount box XDX FBS, an Intercom station can be installed e.g. in a brick wall. The XDX FBS is designed for wall mounting during the construction or renovation phase. To mount the Intercom station, the gypsum wall/panel kit XDX FB is required.



Surface mount kit XDX SHE

With the surface mount kit XDX SHE, an Intercom station can be mounted on a wall. The XDX SHE is primarily intended for subsequent installation on a wall or for installation on thin walls. The XDX SHE provides extra space to install accessories (e.g. EB3E2A-AUD, AFIL-USB or IP-BRIDGE).



Dummy module for RFID readers XDX FBDUR

With the dummy module XDX FBDUR, RFID readers from 3rd-party systems can be installed using the same design as the Intercom station. The special materials of the XDX FBDUR ensure that electromagnetic signals from an RFID reader can be transmitted ideally.



Mounting kit XDX SHMM

With the mounting kit XDX SHM, a surface mount kit XDX SH or XDX SHE can be mounted to a door mullion.



Power injector PA 25W POE-DC

In applications where PoE sourcing equipment is not available, the optional power injector PA 25W POE-DC offers a compact, convenient solution. It supports a wide DC input range (24–48 V) and is IEEE 802.3af/at compliant. The power injector connects easily and conveniently to a station through an Ethernet cable.



Safety switch box IP Secure Connector

The IP Secure Connector provides high performance and high, absolute security, even if the connected Intercom station is located outdoors: If an unauthorised attempt is made to remove the Intercom station, e.g. to access the connected Ethernet cable, the IP Secure Connector interrupts the connection to Intercom station and LAN. This ensures that it is neither possible to access the network nor to open a door or gate. Furthermore, the IP Secure Connector provides power supply in form of PoE+ and has two inputs and three outputs.



Expansion module EB3E2A-AUD

The EB3E2A-AUD expansion module provides an easy way to expand the I/O and audio capabilities of a station. The expansion module is suitable for any applications where inputs and outputs are required. It has three inputs, two output relays and ports for direct connection of an external loudspeaker, external microphones and handset. Line-in and line-out connectors provide additional flexibility. The board can be connected to the station PCB through a USB cable and is immediately available in the system.



Induction loop kit AFIL-USB

With the AFILUSB, a station can easily and quickly be equipped with an induction loop amplifier module. For this, only a free USB jack is required at the station. Thanks to its compact size, the AFIL-USB fits easily into a flush or surface mounting box.



USB I/O module EB1E1A

With the USB I/O module EB1E1A, a base module can be expanded with an input and a relay output (normally open contact). The EB1E1A can be connected to a free USB port. By doing this, a input as well as a floating, galvanically-isolated output contact is available immediately – e.g. for use with a door opener.



Note:

It is possible to connect external USB devices to the device. The device supports the connection of a maximum of one USB device of the same type at any time. Example: One EB3E2A-AUD and one EB1E1A.

System overview

Serverless operation

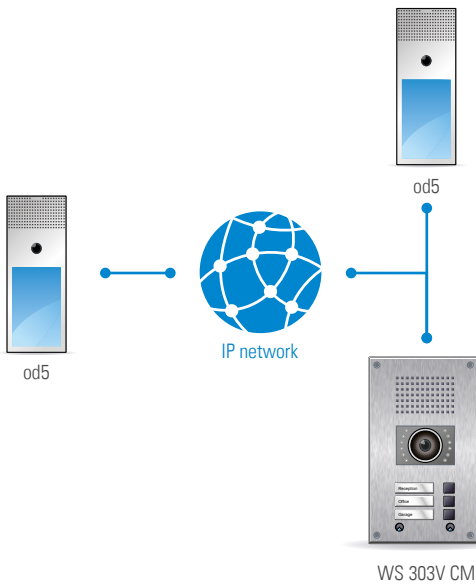

Operation with server

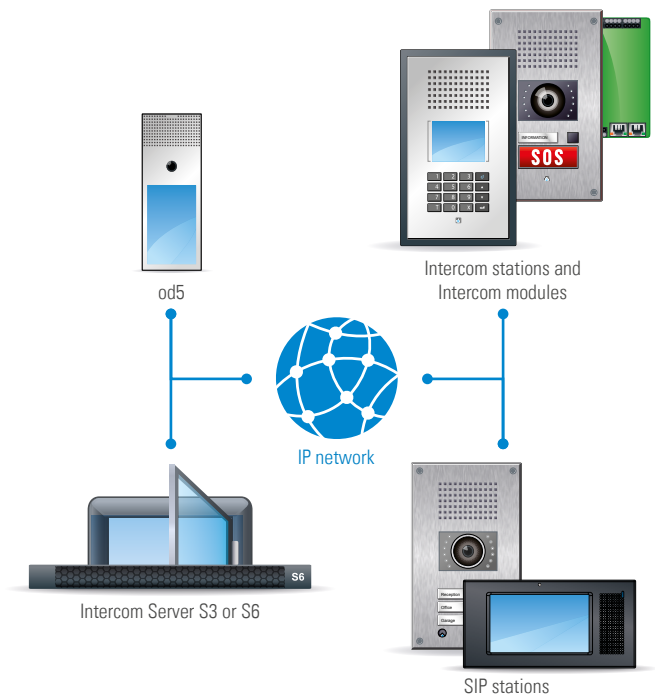

Wall application examples

od5 with EB1E1A (1 output for door opener, connected via USB)

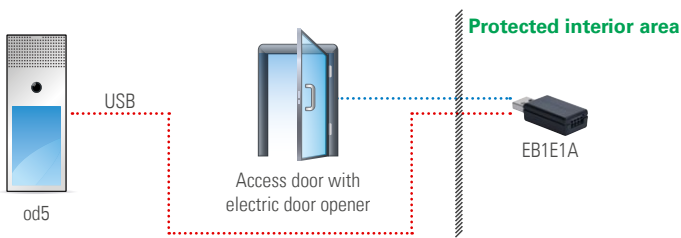

od5 with EB3E2A-AUD (3 inputs, 2 outputs, connected via USB)

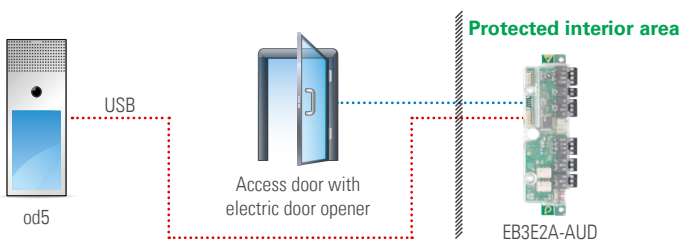

od5 with IP Secure Connector (door opener, network security and PoE, connected via Ethernet)

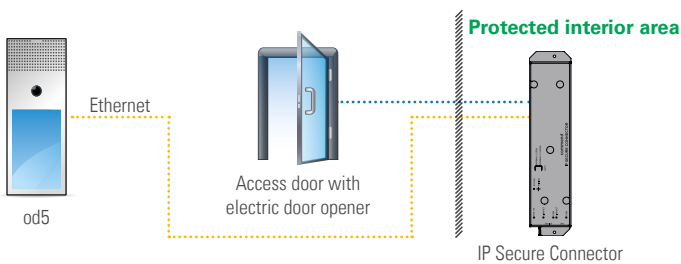

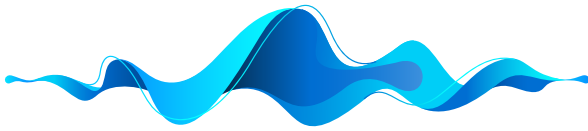

CERTIFIED
ACC. TO
ISO 27001

Passion meets audio

Ultimate speech intelligibility

Because every word matters, high speech intelligibility is crucial in security and communication solutions. In everyday life, it enables natural and brilliant communication; in operational processes, it ensures improved efficiency and in an emergency often buys life-saving time.

High volume

When there is ambient noise, the Intercom station has sufficient reserves to put out the audio signal of the other party at a higher volume than any distracting background sounds.

Dynamic volume adjustment

IVC (Intelligent Volume Control) automatically adjusts the volume of the Intercom station's audio signal to the environment – because both, too low and too high a volume, significantly reduces speech intelligibility and the user experience.

Background noise suppression

To ensure that the other party clearly understands what is being said despite high levels of ambient noise, dynamic background noise suppression together with **beamforming** reduces interfering signal components effectively.

Hands-free communication through OpenDuplex®

This technology from Commend, combined with highly sensitive microphones as well as a high volume, allows natural and hands-free communication within a unique radius of several metres.

Audio functions adding value

Loudspeaker/microphone surveillance – constant availability of Intercom stations while greatly reducing the manual testing effort.

Simplex mode – for applications requiring controlled communication, e.g. security or industrial solutions based on the push-to-talk/release-to-listen principle.

Audio monitoring – fully automated (emergency) call triggering at defined sound pressure levels for more safety.

Live sound pressure level – continuous measurement of ambient noise with optional transfer to a management system through SNMP or HTTPS (e.g. to visualise noise volumes).

Equalizer – for fine-tuning to ambient acoustic conditions.

Public address functions – as an essential element of a holistic solution approach, announcements can be made or played back at each Intercom station as well as responded to directly.

For more information, visit:

audio.commend.com

Cyber security at Commend

Uncompromising protection against threats

IT infrastructures are facing a growing variety of cyber threats. This means that the defensive capabilities of each product in the system environment are key.

Security is above all a question of trust. At Commend, cyber security as a core competence has always been given a very high priority. From the initial product idea through implementation and operational support, privacy and security by design (PSBD) is the uncompromising target and promise to our customers against which product features and functions must be measured.

Cyber security as top priority

- Commend as well as the hardware and software development process is rigorously certified according to the standard **IEC/ISO 27001** and subject to a company-wide information security management system (ISMS)
- Commend is a member of the **Center for Internet Security (CIS)**
- Commend's Cyber Security Board ensures the handling and transparent communication of security vulnerabilities as well as the strategic hardening of Commend systems
- Commend continuously publishes software updates with security patches and improvements

Physical security

- Robust devices and vandal-resistant product versions
- Tamper detection through electromechanical contacts
- USB and port-debugging protection

Network security

- **Standard IEEE 802.1x** for authentication (network access)
- **Standard IEEE 802.1q** for VLANs (network segmentation)
- Commend IP Secure Connector for automatic interruption of the network connection in the event of a tampering attempt

Data security

- **Encrypted and authenticated communication**
- **SIP over TLS v1.2** with secure cipher suites (> 128 bit)
- **SRTP** for tap-proof encryption of voice data
- **X.509 client certificates** for authentication and encryption
- TLS transport encryption for the protocols **HTTPS**, **SIPS** and **MQTT** to protect the web interface, APIs and video

Application security

- Mandatory change of the default password during the first login
- Minimum password length: 12 characters
- Detection of brute-force attacks at login
- Documentation and securing of network ports

Information about the cyber security of other Commend products can be found in the respective data sheets and product manuals.

For more information, visit:

trust.commend.com

od5

Technical specifications

Technical data od5

IP rating:	IP65 (acc. to EN 60529)
Mechanical impact resistance:	IK08 (acc. to EN 62262)
Salt spray test:	672 h (acc. to IEC 60068-2-11/EN 9227)
Front panel:	hardened glass, AG85, 3 mm (0.12 in)
Microphone:	two digital MEMS microphones
Loudspeaker:	special membrane type for optimal sound quality
Amplifier:	integrated class-D amplifier with 2.5 W
Sound pressure level:	max. 95 dB at 0.5 m (1.6 ft)/89 dB at 1 m (3.3 ft)
Display:	5" touch display (TFT) resolution: 720 x 1280 pixel luminance: typ. 800 cd/m ²
Audio bandwidth:	up to 20 kHz
Audio codecs:	Opus, G.722, G.711 a-law and G.711 u-law
Video features:	codecs: H.264 (SIP video and ONVIF), Motion JPEG (HTTP video and ONVIF) and RTSP ONVIF specification: ONVIF Profile S
IT security:	SIP over TLS, SRTP, IEEE 802.1X, MJPEG via HTTPS, HTTPS for accessing the web interface and interfaces
Protocols:	IPv4, IPv6, TLS, TCP, UDP, HTTP (RFC 2617, RFC 3310), HTTPS (RFC 2818), RTP (RFC 3550), 802.1x EAP-TLS (RFC 5216), 802.1x EAP-MD5 (RFC 2284), RTCP, RTSP (RFC 2326), DHCP, DHCPv6, SDP (RFC 2327, RFC 4566), SSDP, SIP (RFC 3261), SIP over TLS, SNMPv2c, STUN (classicstun), SMTP, DTMF Decoding (RFC 2976, RFC 2833, SIP Info), ICMPv6 (Router discovery), MQTT (ISO/IEC 20922))
Storage temperature range:	-25 °C to +55 °C (-13 °F to +131 °F)
Storage temperature range:	-25 °C to +70 °C (-13 °F to +158 °F)
Relative humidity:	up to 95%, not condensing
Connection:	RJ45 jack for Ethernet and PoE (10/100 Mbit/s) 2 x 2.0 USB (Type A) for external devices ¹⁾
Power supply ²⁾:	PoE: IEEE 802.3af/Class 0, IEEE 802.3at/Type 1
Cabling:	min. Cat. 5, shielded ³⁾
Approvals and compliances:	EN 61000-6-2, EN 61000-6-3, EN 55032 Class B, EN 55024, EN 60529 IP65, EN 62262 IK07, IEC 60068-2-11, EN 62368-1
Wall mounting:	gypsum wall/panel mount kit XDX FB flush mount box XDX FBS (requires XDX FB) surface mount kit XDX SH
Dimensions (H x W x D):	with flush mount kit: 228 x 86 x 11 mm (8.98 x 3.38 x 0.43 in) with surface mount kit: 228 x 86 x 35 mm (8.98 x 3.38 x 1.38 in)
Weight incl. packaging:	approx. 600 g (1.32 lbs)
Optional accessories:	AFIL-USB (induction loop kit) EB1E1A (USB I/O module) EB3E2A-AUD (expansion module) PA 25W POE-DC (power injector) IP Secure Connector (safety switch box)



Technical data camera

Image sensor:	1/3 in RGB CMOS
Lens:	F2.4, fixed aperture, 130° diagonal angle, 125° horizontal angle, 100° vertical angle
Minimum illumination:	B/W: 1 lux colour: 1.5 lux
Resolution (W x H):	1280 x 960 pixels
Frame rate:	up to 30 fps
Video streaming:	up to 6 HTTP video streams simultaneously

Extent of supply

- Intercom station
- Microfiber cloth
- TX 08 screwdriver
- Claiming code
- Short reference

System requirements

Server

- VirtuoSIS (min. version 5.0) or
- S3/S6 (min. version 7.1) or
- Compatible SIP server or
- Serverless operation

Configuration software

- Set-UP min. version 1.5.3

Access

The device can be accessed through IPv4 (DHCP), IPv6 (link-local) and zero-conf. For information on accessing the web interface, see the product manual.

¹⁾ The USB connections are only intended for use with Commend devices. Do not use the USB jacks e.g. to charge mobile phones.

If a USB device should be installed separately using a USB extension cable, the USB cable length must not exceed 5 m. In addition to that, it is recommended to attach a ferrite to a USB cable with a length of 1 m or more.

²⁾ For power supply, a PoE switch or PoE injector is required (not included in extent of supply), e.g. IP Secure Connector.

³⁾ The maximum line length of Cat. 5 cabling in a LAN is 100 m (328 ft) – e.g. from switch to Intercom station.

od5

Installation instructions

Installation instructions

- Avoid direct sunlight.
- Install the Intercom station with a distance of min. 150 mm (6 in) downwards to enable access to the locking screw (Tx08).
- For installing the Intercom station, the following mount kits are available separately: XDX FB, XDX SH, XDX SHE, XDX SHMM, XDX SHID. For mounting details, see corresponding short reference of the mount kit.
- Do not install the Intercom station on unstable walls or on surfaces which cannot support the device's weight.
- Make sure the mount kit is not subject to torsional forces (e.g. on uneven walls).
- No water may penetrate into the mount kit.
- For mounting with the surface mount kit XDX SH or the gypsum wall/panel mount kit XDX FB, it is not possible to use an Ethernet field cable with crimp connector for direct connection to the device due to space limitations.
- If a field cable is used, it is recommended to install an RJ45 crimp jack (e.g. MODJ8-8KUPPL) at the open end of the field cable. Use a patch cable to connect the device to the RJ45 crimp jack.
- Use shielded Ethernet cables only.
- Before using the device, ensure all cables are correctly connected and not damaged.
- Use moistened microfibre cloths for cleaning the Intercom station.

Recommended mounting height

The upper edge of the Intercom station approx. 1,650 mm (65 in) from the finished floor. Adapt the mounting height to the individual needs.

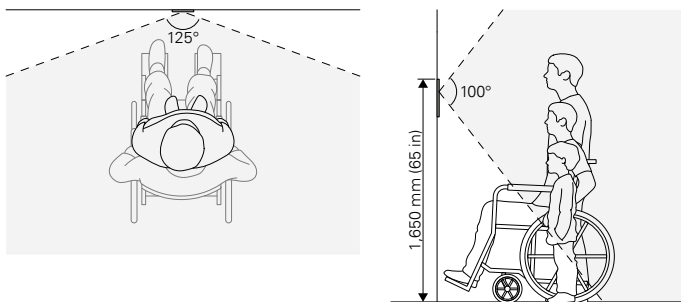

NOTES:

- For a barrier-free accessibility, it is recommended to mount the Intercom station with sufficient distance to walls or corners.
- When mounting the Intercom station OD5 TD CM, pay attention to the correct camera angle in terms of accessibility so that wheelchair users and children can be detected by the camera:
100° (vertical) x 125° (horizontal)

Safety instructions

- This Intercom station shall be installed or replaced by trained and qualified personnel only.
- Observe the country-specific standards for installation, mounting and configuration.
- Only use Commend accessories that comply with the Intercom station's technical specifications.
- All connected circuits shall fulfil the following requirements:
 - Safety Extra Low Voltage (SELV) and Limited Power Source (LPS) according to IEC/EN 60950-1 or
 - ES1, PS2 circuits and Annex Q (Limited Power Source) according to IEC/EN/UL 62368-1.
- The front of the Intercom station is made of glass. Do not use the Intercom station when the glass is damaged.
- Disconnect the Ethernet cable for any maintenance of the device.
- Do not make any modifications to the Intercom station.
- This equipment has been tested and found to comply with the limits for a Class B digital device, pursuant to part 15 of the FCC Rules. These limits are designed to provide reasonable protection against harmful interference in a residential installation. This equipment generates, uses and can radiate radio frequency energy and, if not installed and used in accordance with the instructions, may cause harmful interference to radio communications. However, there is no guarantee that interference will not occur in a particular installation. If this equipment does cause harmful interference to radio or television reception, which can be determined by turning the equipment off and on, the user is encouraged to try to correct the interference by one or more of the following measures:
 - Reorient or relocate the receiving antenna.
 - Increase the separation between the equipment and receiver.
 - Connect the equipment into an outlet on a circuit different from that to which the receiver is connected.
 - Consult the dealer or an experienced radio/TV technician for help.

Dimensions

OD5 TD CM

Measuring units in mm (in), not to scale!

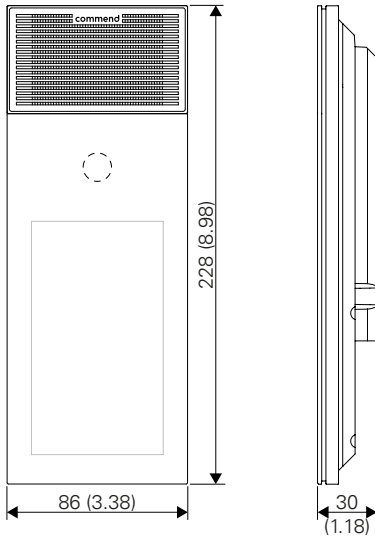

Surface mount kit XDX SH

Measuring units in mm (in), not to scale!

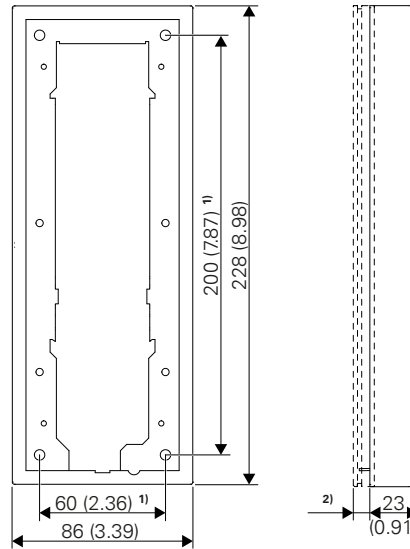

¹⁾ Dimensions for wall holes (ø 5 mm/0.2 in)

²⁾ Dimensions of the Intercom station

Surface mount kit XDX SH

Measuring units in mm (in), not to scale!

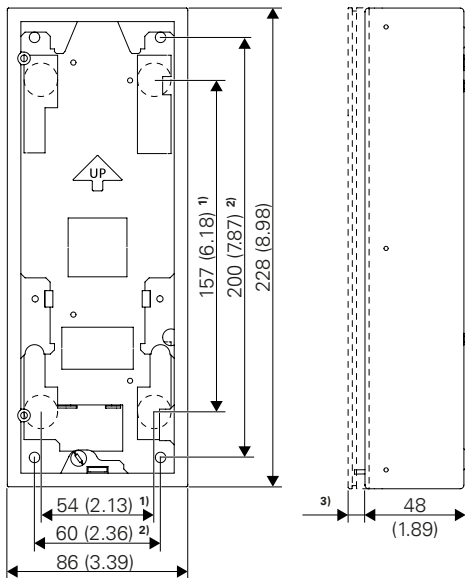

¹⁾ Dimensions for cable feed-through (ø 14 mm/0.55 in)

²⁾ Dimensions for mounting holes (ø 5 mm/0.2 in)

³⁾ Dimensions of the Intercom station

Door mullion mount kit XDX SHMM

Measuring units in mm (in), not to scale!

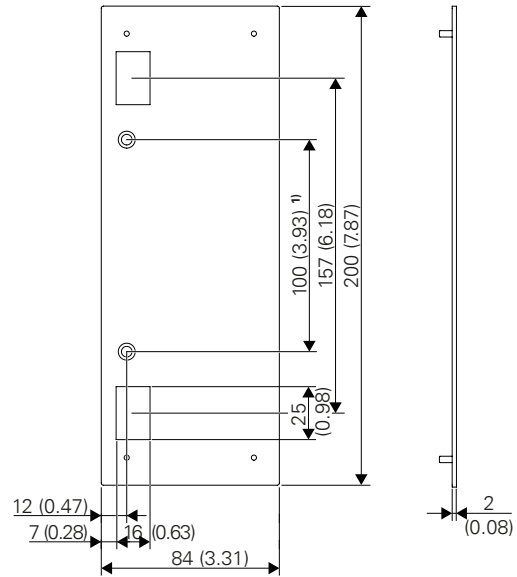

¹⁾ Dimensions for boreholes (ø 5 mm/0.2 in)

Gypsum wall/panel mount kit XDX FB

Measuring units in mm (in), not to scale!

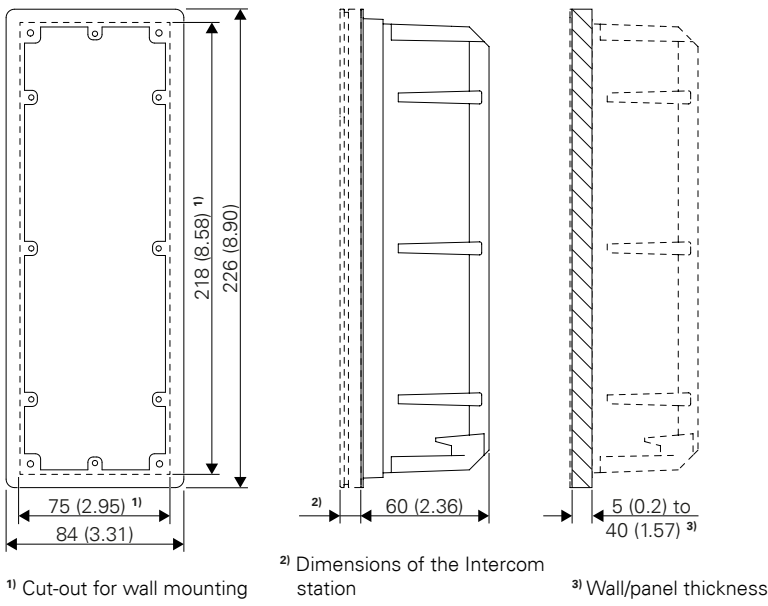

Flush mount box XDX FBS

Measuring units in mm (in), not to scale!

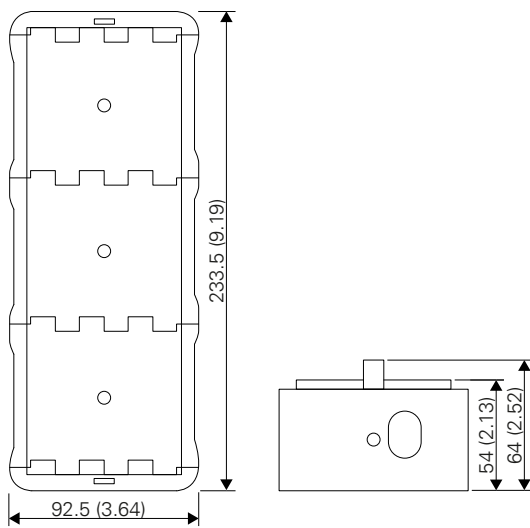

NOTE:

For mounting of an Outdoor series Intercom station in the flush mount box XDX FBS, the gypsum/panel mount kit XDX FB is required.

Wall mounting with XDX FB

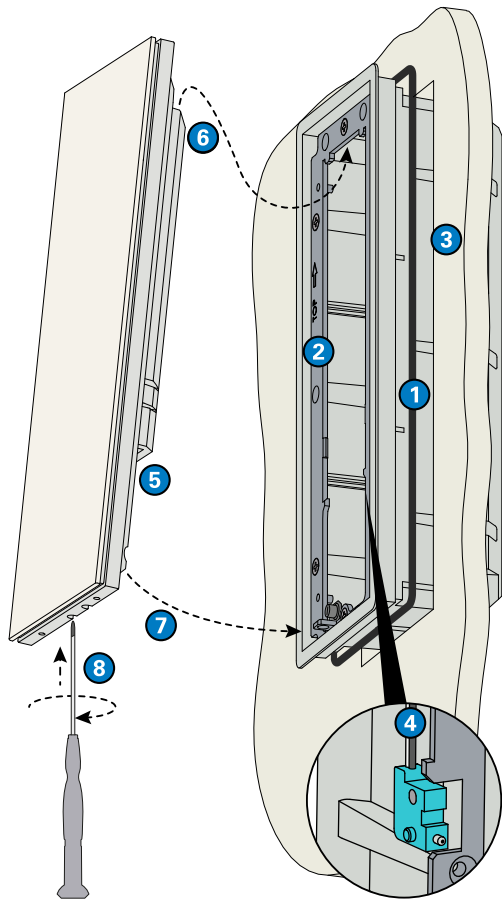

- 1 If necessary, stick the supplied gasket onto the mounting box.
- 2 Make sure the arrows on the mounting frame point upwards.
- 3 Install the mounting box to the wall by means of the supplied drilling template. Press the four claw clamps on the sides of the mounting box outwards and tighten them using the corresponding screws (PZD2).
- 4 If required, mount the tamper switch TAMP-KIT (not included in the extent of supply; for mounting details, see respective short reference).
- 5 Connect the cables.
- 6 Insert the Intercom station at the top of the mounting frame.
- 7 Press the Intercom station with its lower end onto the mounting box.
- 8 Turn the locking screw anti-clockwise down as far as it will go using the TX8 screwdriver (included in the extent of supply of the Intercom station). Check whether the lower end of the Intercom station is fixed on the mounting frame.

NOTE:

For mounting on brick walls, additionally the flush mount box XDX FBS is required (not included in the extent of supply). In this case, mount the flush mount box XDX FBS in the wall and then continue with 1.

Surface mounting with XDX SH

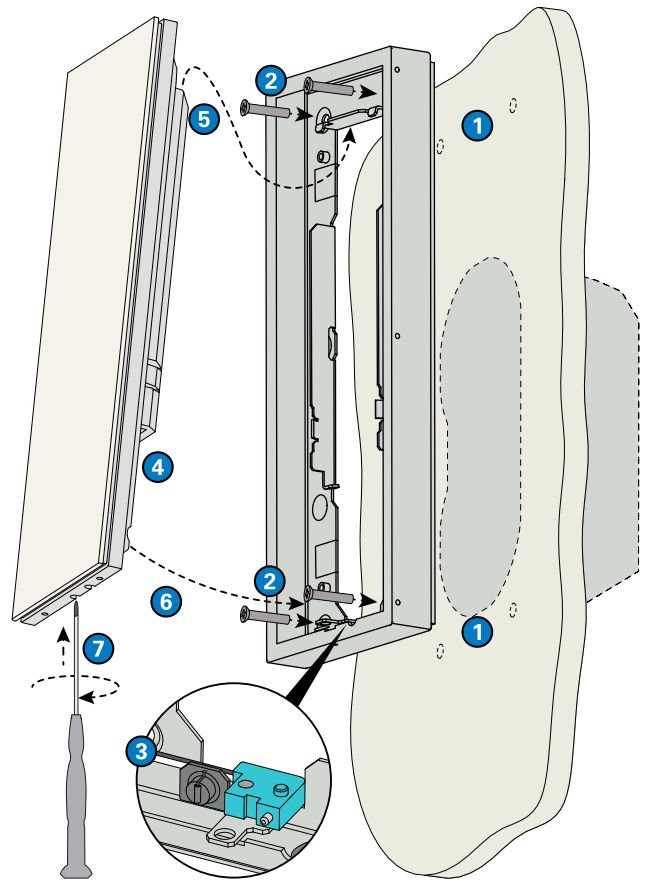

- 1 Drill four holes in the wall (see "Dimensions") and insert the supplied wall plugs.
- 2 Install the surface mount kit to the wall using the supplied mounting screws (the locking element must be at the lower end).
- 3 If required, mount the tamper switch TAMP-KIT (not included in the extent of supply; for mounting details, see respective short reference).
- 4 Connect the cables.
- 5 Insert the Intercom station at the top of the surface mount kit.
- 6 Press the Intercom station with its lower end firmly onto the surface mount kit.
- 7 Turn the locking screw anti-clockwise down as far as it will go using the Tx08 screwdriver (included in the extent of supply of the Intercom station). Check whether the lower end of the Intercom station is fixed on the surface mount kit.

Surface mounting with XDX SHE

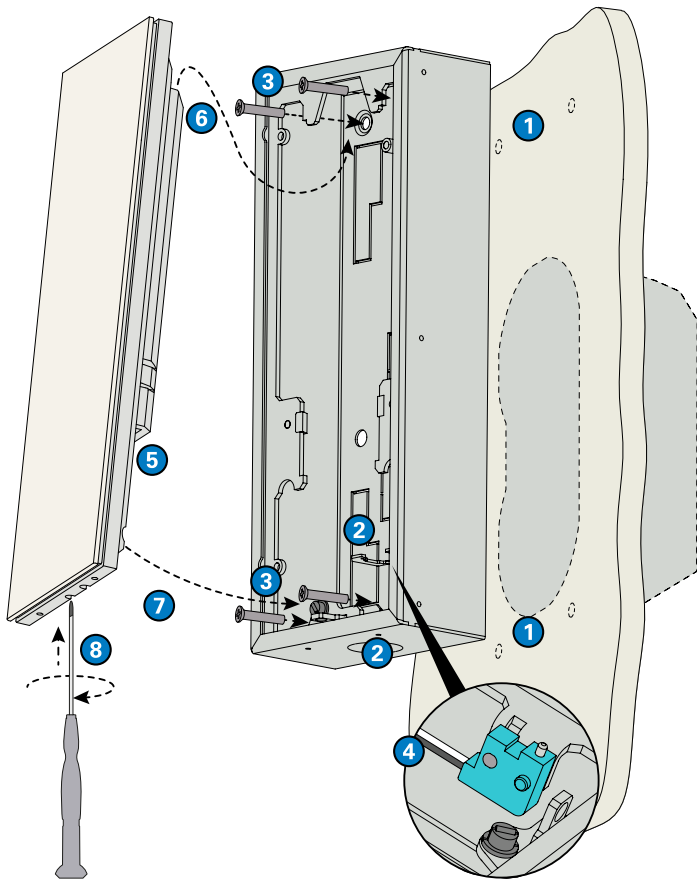

- 1 Drill four holes in the wall (see "Dimensions") and insert the supplied wall plugs.
- 2 Break out one of the provided cable entries depending on cable supply (see also hatched areas at "Mounting points"). Guide the required cables (Ethernet and USB cable, if needed) through the cable entry.
- 3 Install the surface mount kit to the wall using the supplied mounting screws (the arrow "UP" must point upwards).
- 4 If required, mount the accessories (not included in the extent of supply; see "Mounting points").
- 5 Connect the cables.
- 6 Insert the Intercom station at the top of the surface mount kit.
- 7 Press the Intercom station with its lower end firmly onto the surface mount kit.
- 8 Turn the locking screw anti-clockwise down as far as it will go using the Tx08 screwdriver (included in the extent of supply of the Intercom station). Check whether the lower end of the Intercom station is fixed on the surface mount kit.

Surface mounting with XDX SHMM

Mounting with XDX SH

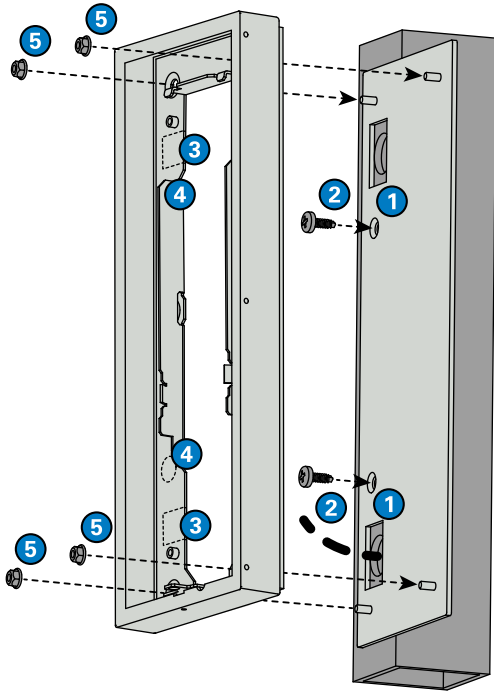

Mounting with XDX SHE

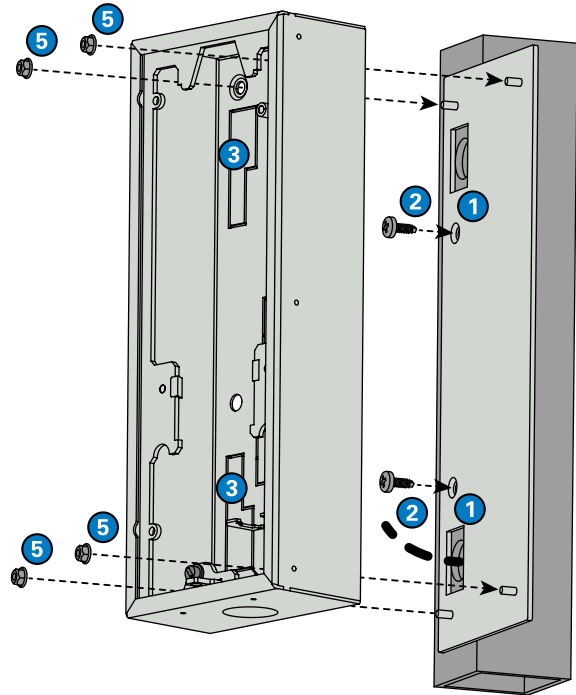

- 1 Drill two mounting holes in the door mullion (see "Dimensions"). A borehole with a diameter of 3.5 mm is required for the supplied self-tapping screws. Prepare a hole for the cable gland.
- 2 Mount the mounting plate on the door mullion using two self-tapping screws so that the mounting bolts face away from the door mullion. Guide the cable through the opening. The mounting kit is symmetrical and can be installed with the openings on the left or right. It is recommended to seal the mounting plate to the door mullion.
- 3 Depending on the mounting side, break out the provided cable openings.
- 4 (Mounting with XDX SHE only) Depending on the mounting side, break out the mounting holes.
- 5 Mount the surface mount box XDX SH or XDX SHE on the mounting plate using the four nuts.

Quality tested. Reliable. Smart.

COMMEND products are developed and manufactured by Commend International in Salzburg, Austria.

The development and manufacturing processes are certified in accordance with **EN ISO 9001:2015**.



The technical data contained herein has been provided solely for informational purposes and is not legally binding. Subject to change, technical or otherwise. lolP®, OpenDuplex® and Commend® are trademarks registered by Commend International GmbH. All other brands or product names are trademarks or registered trademarks of the respective owner and have not been specifically earmarked.

A strong worldwide network

COMMEND is represented all over the world by local Commend Partners and helps to improve security and communication with tailored Intercom solutions.

www.commend.com